



FITTING INSTRUCTIONS

New EGR

Application for
VAG

Part numbers
700490

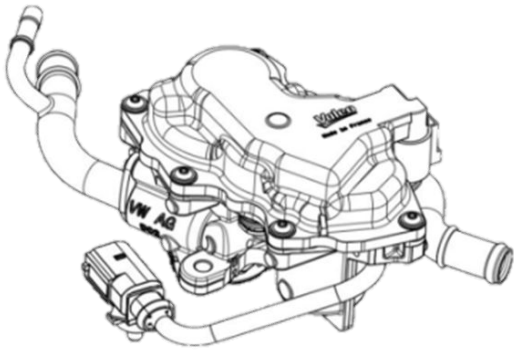

The new system for EGR

The Valeo´s p/n **700456** has been replaced by new Valeo´s p/n **700490**

The new reference is deliver **without the cast iron body** so the new EGR will be mounted in the current housing

New EGR valve



Cast iron body housing

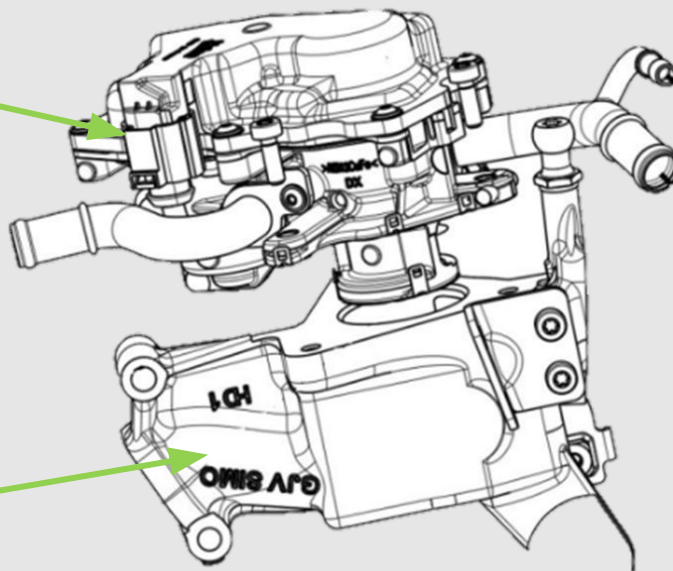
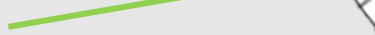

Website
valeoservice.us/en-us



Technical Assistance
1-888-718-2536 valeoservice.us



DISASSEMBLY OF EGR



STEP 1
Disconnect the EGR connector
 Disconnect the EGR connector from the engine harness



STEP 2
Removing the EGR connector clip
 Remove the EGR connector clip from its fixation point by using the appropriate tool to avoid damaging the connector

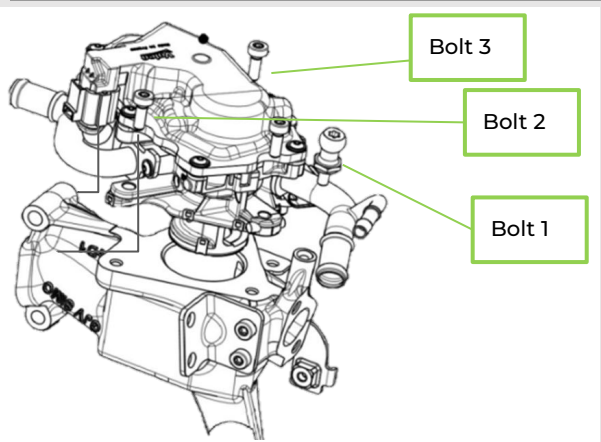

STEP 3
Bolt removal
 Remove the bolts 3,2 & 1 respectively

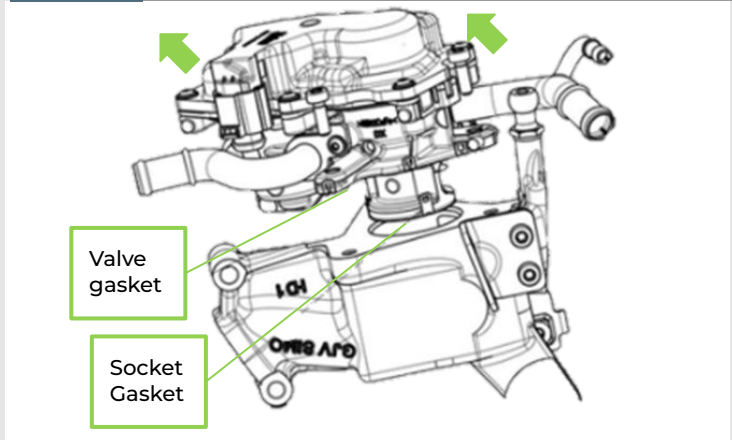

STEP 4
Remove the EGR from its housing
 By using Screw hexalobular socket head screw M6x18 take off the EGR valve including the valve gasket and socket gasket

ASSEMBLY OF THE NEW EGR

Valeo provides in the **new EGR valve gasket**, the **3 bolts** and the **socket gasket** assembled into the EGR valve

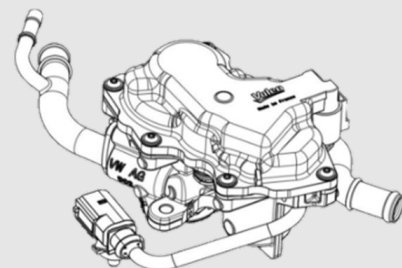

Website
valeoservice.us/en-us



Technical Assistance
1-888-718-2536 valeoservice.us



PARTS PROVIDED WITH THE NEW EGR

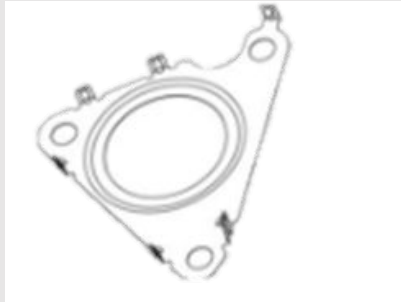

Part 1 Valve gasket



Part 2 Socket gasket



Part3 Hexalobular socket head bolt M6 x 18

STEPS OF ASSEMBLY OF EGR

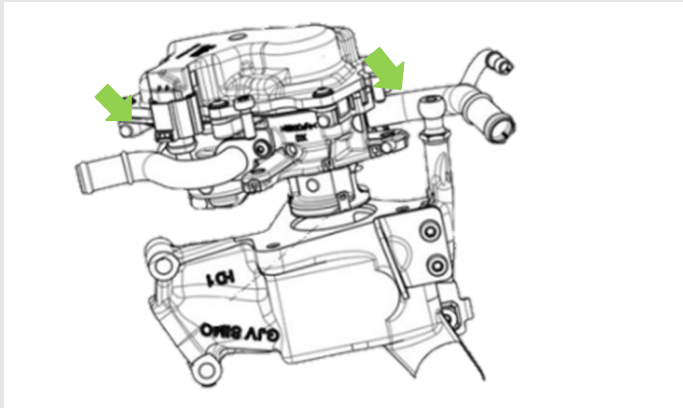

STEP 1

Installation of EGR

Install the EGR on the iron body as per shown in picture

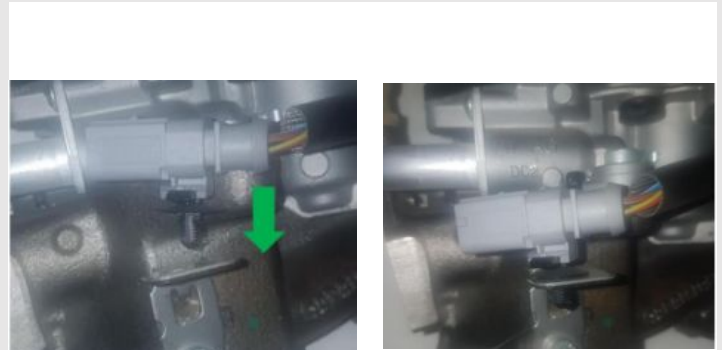

STEP 2

Clip installation

Install the clip back to its original position as shown in picture

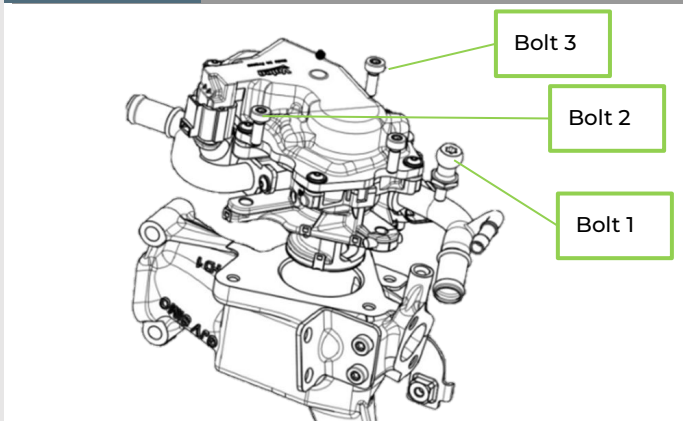

STEP 3

Installation of EGR to its base

Install the EGR to the cast iron base, starts tighten bolt 1, 2 and 3 with **10 Nm** respectively.



STEP 4

Connection of EGR

Connect the EGR connector to the engine harness



Website
valeoservice.us/en-us



Technical Assistance
1-888-718-2536 valeoservice.us

