

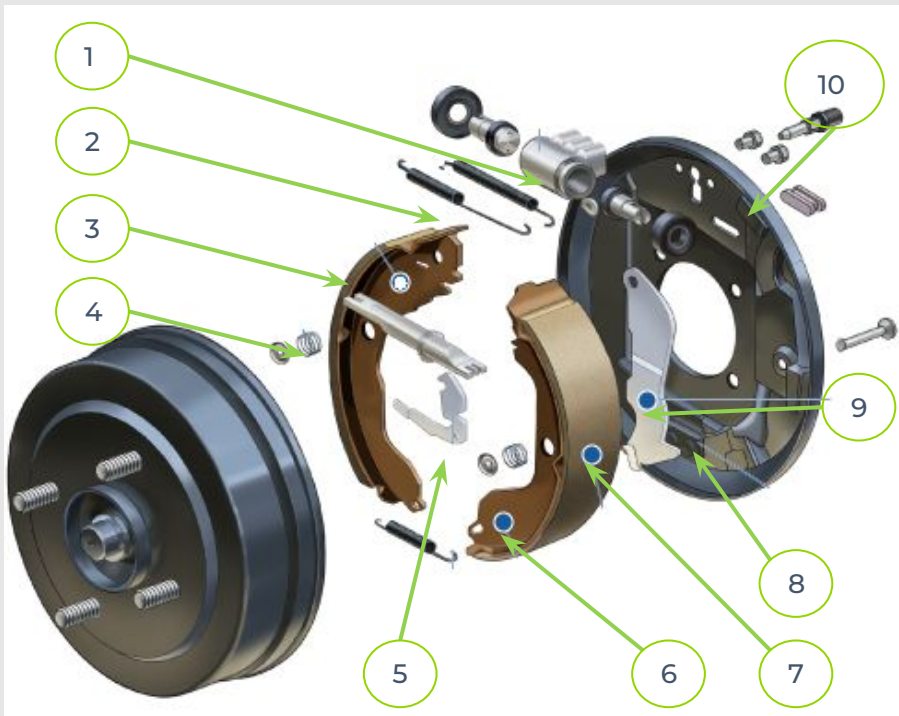

Fitting instructions

Rear Brake shoe

Rear brake shoe component



S	Name
1	Wheel cylinder
2	Return spring
3	Leading shoe
4	Shoe hold spring
5	adjuster level
6	Trailing shoe
7	Lining
8	Anchor
9	Parking level
10	back plate



Important points

- Clean brake lining with a vacuum dust collector to minimize the hazard of airborne materials.
- Make sure parking brake lever and pedal is completely released.

Removal steps

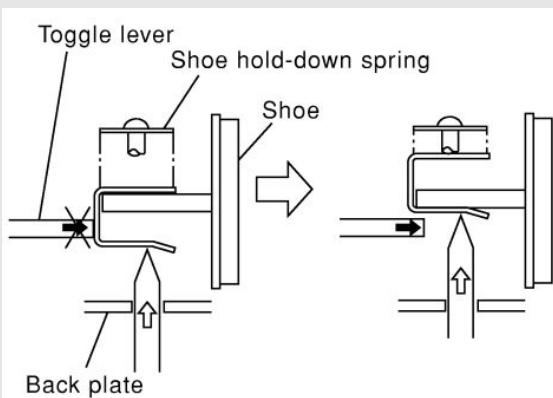

Step 1: Release parking brake lever and pedal fully, then remove drum.
If drum is hard to remove, the following procedures should be carried out.

- Remove plug. To make shoe clearance, push shoe hold-down spring to free toggle lever.
- Install two bolts as shown. Tighten the two bolts gradually

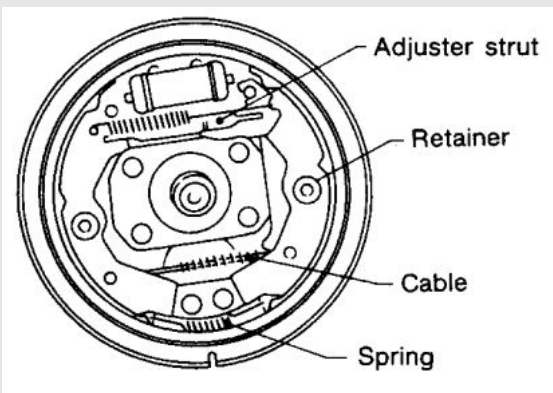
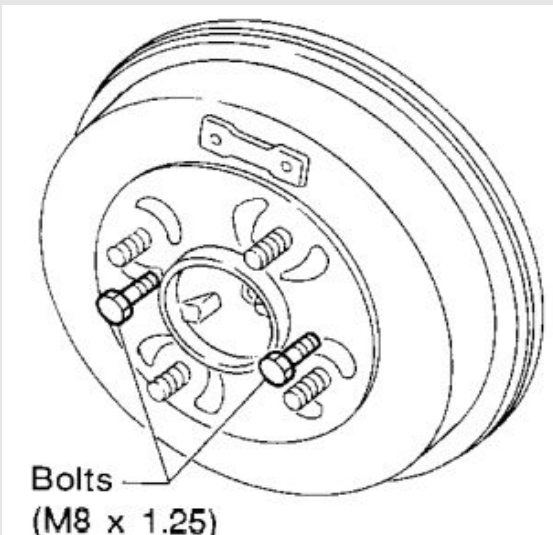

Step 2: After removing retainer;

- Remove spring by rotating shoes.
- Remove adjuster.
- Disconnect parking brake cable from toggle lever

Be careful not to damage wheel cylinder piston boots.

Be careful not to damage parking brake cable when separating it.



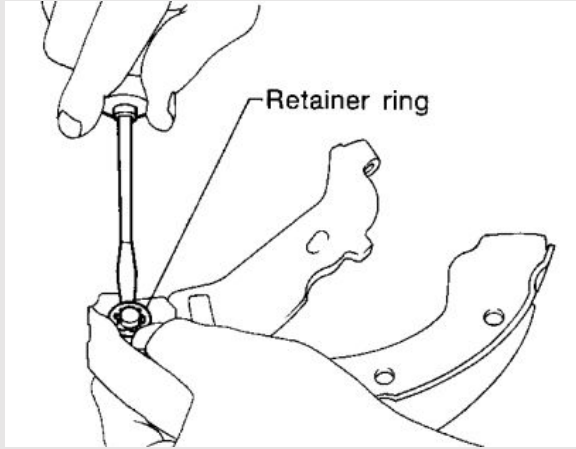

Step 3: Remove retainer ring with a suitable tool. Then separate toggle lever and brake shoe.

Inspection

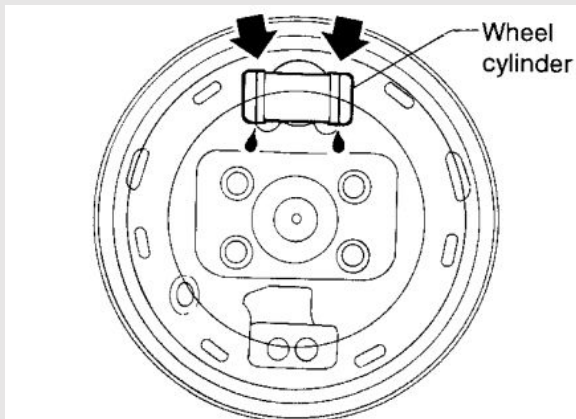

Wheel cylinder:

- Check wheel cylinder for leakage.
- Check for wear, damage and loose conditions. Replace if any such condition exists.

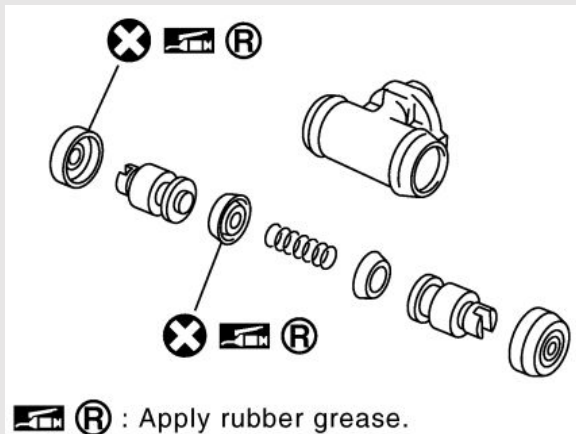

Wheel cylinder overhaul:

- Check all internal parts for wear, rust and damage. Replace if necessary.
- Pay attention so as not to scratch cylinder when installing pistons.



Inspection

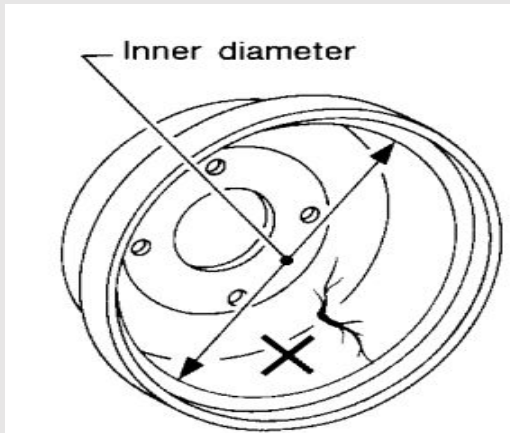

Drums:

- Contact surface should be fine finished with No. 120 to 150 emery paper.
- Using a drum lathe, resurface brake drum if it shows scoring, partial wear or stepped wear.
- After brake drum has been completely reconditioned or replaced, check drum and shoes for proper contact pattern.
- By using the vernier caliper measure the inner diameter of the drums if the result is out of specification replace it.

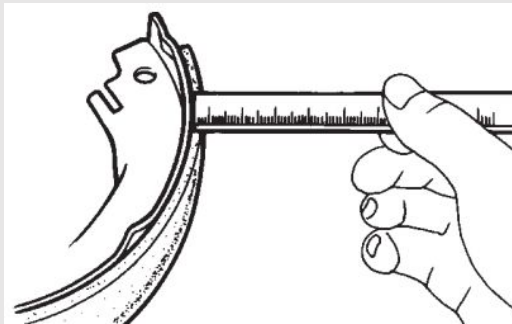

Brake lining:

- check the lining thickness of the brake shoe with rule and compare it

Installation

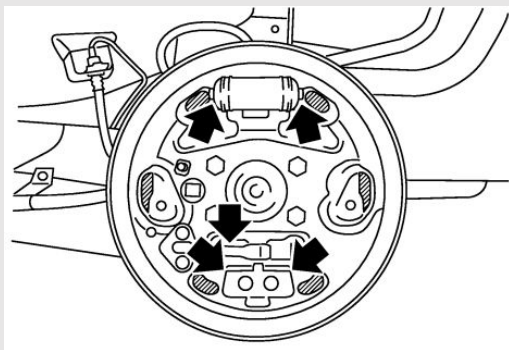

Step 1:

- Fit toggle lever to brake shoe with retainer ring.
- Apply brake grease to the contact areas shown at left.



Installation

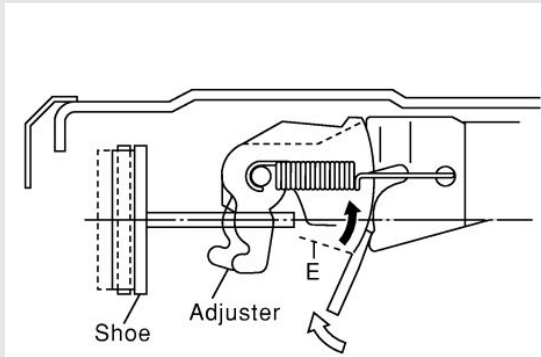

Step 2:

- Shorten adjuster by rotating it.
- To tighten loosened brake shoes, **first**, insert a **screwdriver** in the **direction** shown in the left.
- Move the adjuster in the direction shown by the arrow while disengaging the tooth contact.
- Never tap the area E.
- Connect parking brake cable to toggle lever.
- Install all parts.
- Check all parts are installed properly.
- Install brake drum.
- Adjust parking brake

