

Damaged clutch cover during fitment

The Valeo Warranty team have received several clutch claims where, upon inspection, it has been found that the clutch cover has been damaged. Deformation of the outer edge can be seen either as a result of the clutch cover not being seated correctly on the flywheel during fitment, or the clutch cover has impacted the flywheel shoulder during placement.

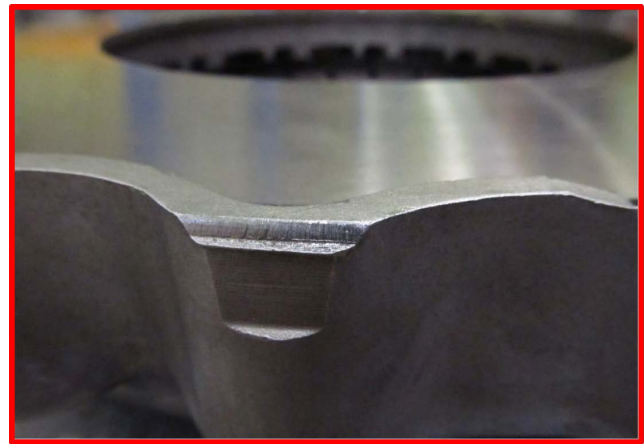

Valeo Service recommend using guidance installation pins when fixing CV clutch covers on their respective flywheels. This ensures that the clutch cover is in its accurate position. If the clutch cover is damaged, it should not be refitted.

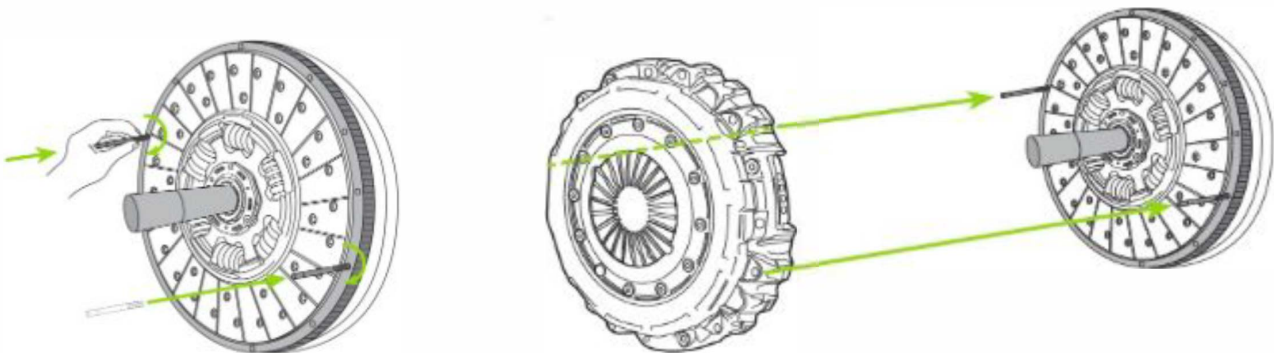

Please note; Valeo Service do not recommend the use of impact drivers to install clutch or flywheel bolts as torque tolerances can not be accurately respected.